

LOC	QTY	ZONE	LTR	DESCRIPTION	DATE	APPD
6	14	A		REVISED PER 0720-0230-93		

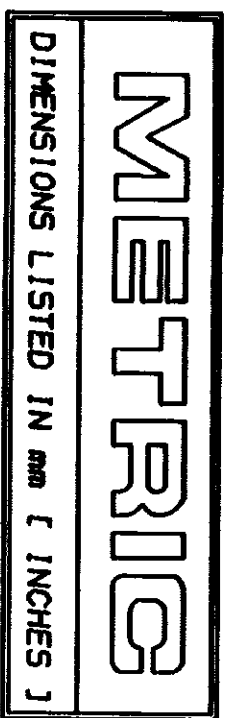

AMP WIRE RANGE 12-10 AWG STRANDED	UL E13288 Listed 12-10 AWG STRANDED
● LR7189 Certified	MILITARY P/N AND CLASS
NOT CERTIFIED	NOT APPLICABLE

△ STAMP AMP 12-10* APPROX AS SHOWN

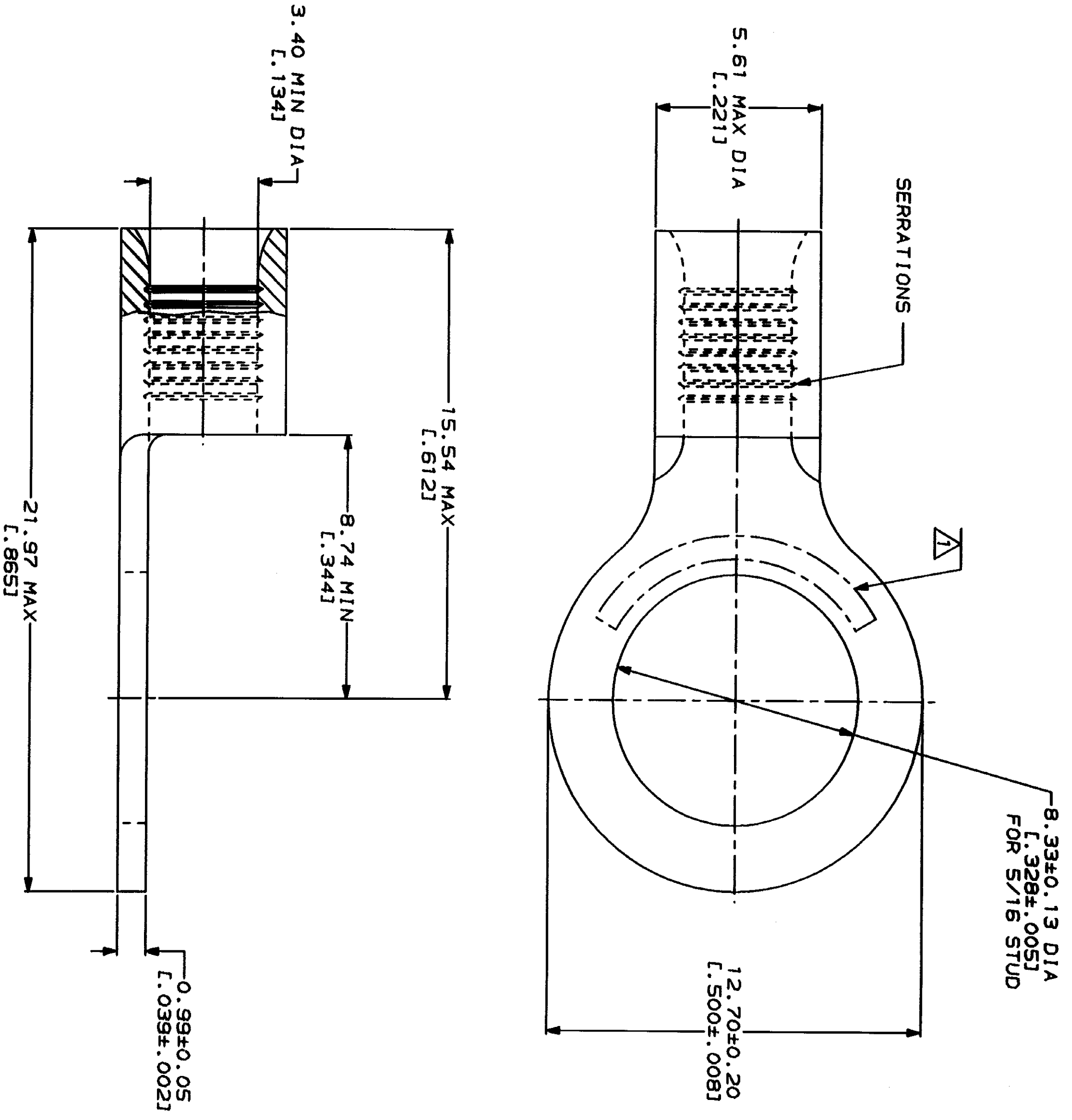

AMP INCORPORATED
 CUSTOMER SERVICE SYSTEMS

FOR ADDITIONAL PRODUCT INFORMATION OR COPIES OF DRAWINGS AND TECHNICAL DOCUMENTS	PRODUCT INFORMATION CENTER 1-800-522-6752	MAX RECOMMENDED OPERATING TEMPERATURE: 170°C MAX	DO NOT SCALE PRINT. UNLESS SPECIFIED DIMENSIONS IN INCHES TOLERANCES ON: 1 PLC DEC ± .005 2 PLC DEC ± .002 3 PLC DEC ± .001 ANGLES
FOR APPLICATION TOOLING INFORMATION	TOOLING ASSISTANCE CENTER 1-800-722-1111	VOLTAGE RATING: NOT APPLICABLE	DR 2-9-93 TA BRINKMAN
FOR ORDER ENTRY	1-800-526-5142	WIRE CROSS SECTIONAL AREA RANGE: 15, 180-13, 100] CIR MILS STRANDED	CHK 2-9-93 DA PATTERSON

FINISH TIN PLATE 0.00254 [L. 000100] MIN THK PER MIL-T-10727	APPD 2-9-93 DE MILLER	NAME AMP AMP Incorporated Harrisburg, PA 17105-3508	DR 2-9-93 TA BRINKMAN
APPLICATION SPEC	APPD 2-9-93 JL MCKELVEY	TERMINAL, RING TONGUE, BUDGET	CHK 2-9-93 DA PATTERSON
WEIGHT	PRODUCT SPEC	SCALE 8:1	APPD 2-9-93 DE MILLER
		CAGE CODE 00779	APPD 2-9-93 JL MCKELVEY
		DRAWING NO 34966	PRODUCT SPEC
		SHEET 1 OF 1	APPLICATION SPEC

CUSTOMER DRAWING

34966
PART NO